

SNO.KJ07073	IRIS	
TYPE	PRESSURIZED	
BUILT	25-DEC-2014	
FLAG	Panama	
CLASS	Class NK	
QUALIFICATION	IMO TYPE II PG	
CALL. SIGN	3EHO3	
TEL NO.	+870 773 206 886	
FAX NO.	+870 783 242 884	
DATA NO.		
E-MAIL ADDRESS	3EHO3@globeemail.com	
TELEX NO.	+ 870 437 207 210	
DW(MT)	3,200.71	
INTERNATIONAL TONNAGE	GRT 2,999.00 / NET 930.00	
DOMESTIC TONNAGE	-	
NET TON	930.00	
LOA (M)	96.00	
BREADTH (M)	15.00	
DEPTH (M)	7.00	
SUMMER DRAFT (M)	5.21	
MAX DRAFT (M)	5.21	
TANK CAPACITY (CBM) - 98% (NUMBER)	Total	3,518.096
	No. 1	1,759.154
	No. 2	1,758.942
MAX. PRESSURE	17.65 Barg	
MIN. TEMP.	0 DEG.C	
CARGO SEGREGATION	ONE GRADE	
LOADABLE CARGOES	Propylene, Propane, B/P Mixtures, Butane, Butadiene, Butylens, Vinyl chloride, Isoprene, Pentanes, Pentene	
I.G.PLANT (CAPACITY) (CONTAINTS)	NITROGEN GENERATOR 200 M3/Hr N2 99.9 vol %	
(LOWEST DEWPOINT ACHIEVABLE)	- 60 Deg.C	
CARGO RE-HEATER(TYPE) (NUMBER) (HEATING MEDIUM) (SPEC FOR PROPANE FROM - 45 TO 0 C)		
CARGO PUMPS(TYPE) (CAPACITY-CBM/HR) (NUMBER)	Deepwell, Centrifugal 300 M3/Hr 2	
CARGO COMPRESSOR (TYPE) (CAPACITY-CBM/HR) (NUMBER)	Vertical 1 stage water cooled double acting 460 M3/Hr 2	
MAIN ENGINE (SERVICE POWER)	IFO 380 CST 2,080 Kw @ 80%	

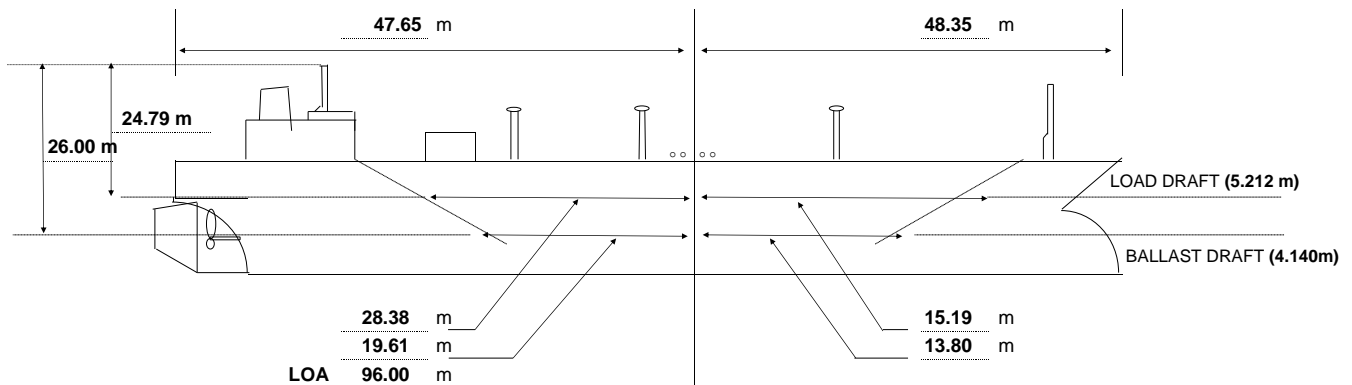

MANIFOLD

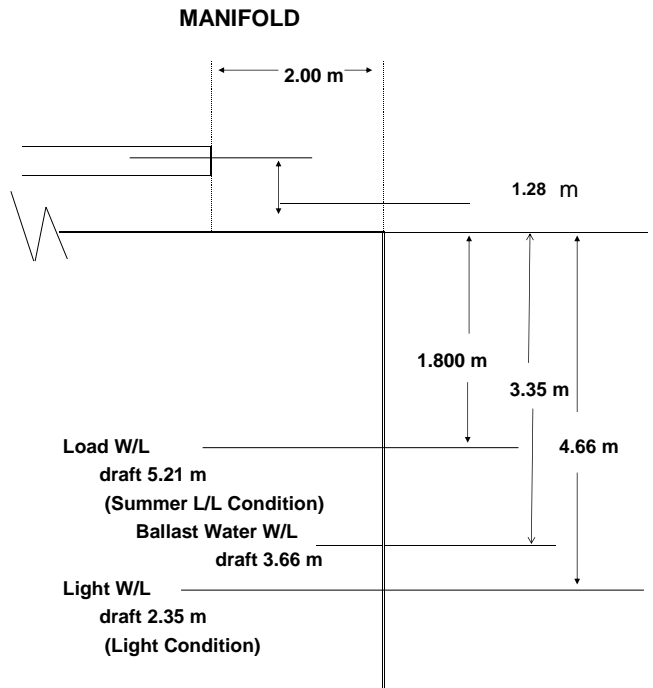
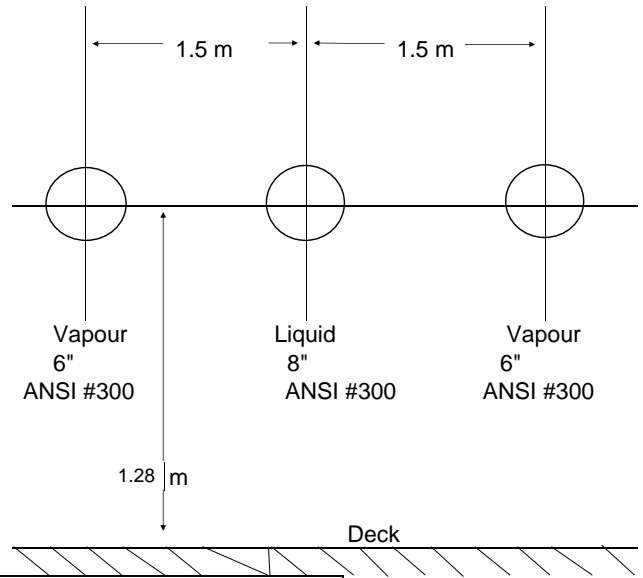