

SNO. 1312	LOTUS CORAL
TYPE	PRESSURIZED
BUILT	23 JAN 2013
FLAG	PANAMA
CLASS	Nippon Kaiji Kyokai (NKK)
QUALIFICATION	IMO TYPE 2PG
CALL. SIGN	3EXZ8
TEL NO.	773 152 290
FAX NO.	783 202 180
DATA NO.	
E-MAIL ADDRESS	master.lotuscoral@amosconnect.com
TELEX NO.	435 455 511
DW(MT)	3,829.84
INTERNATIONAL TONNAGE	GRT 3,422 / NRT 1,027
DOMESTIC TONNAGE	
NET TON	1,027.00
LOA (M)	97.69
BREADTH (M)	16.00
DEPTH (M)	7.20
SUMMER DRAFT (M)	5.413
MAX DRAFT (M)	5.413M DISPLACEMENT 6,081.28 MT (3,829.84 DWT) IF0=385 MT, MDO=83 MT, L/O=50MT, F/W=165 MT, B/W=20 MT
TANK CAPACITY (CBM)	Total 3,518.882
(NUMBER)	No. 1 1,759.760 No. 2 1,759.122
MAX. PRESSURE	1.77 Mpa (18.0 KG/CM2)
MIN. TEMP.	0 DEG.C
CARGO SEGREGATION	ONE GRADE
LOADABLE CARGOES	Propylene, Propane, Pentene, B/P Mix Butane, Butadiene, Butylene, VCM, Isoprene
I.G.PLANT	NITROGEN GENERATOR
(CAPACITY)	200 m3/hr
(CONTAINTS)	AR 1.2 %, CO2 3 PPM HC 4 PPM, H2O 2 PPM O2 0.1 %, N2 REMAIN
(LOWEST DEWPOINT ACHIEVABLE)	- 60 C
CARGO RE-HEATER(TYPE)	Horizontal Shell and Tube Type
(NUMBER)	1
(HEATING MEDIUM)	Sea Water
(SPEC FOR PROPANE FROM - 45 TO 0 C)	250CM3/Hr
CARGO PUMPS(TYPE)	DEEPWELL
(CAPACITY-CBM/HR)	300/250 (VCM)
(NUMBER)	2
CARGO COMPRESSORE (TYPE)	Vertical water-cooled 1 stage double acting oil-less
(CAPACITY-CBM/HR)	460 m3/hr
(NUMBER)	2
MAIN ENGINE	DIESEL
(SERVICE POWER)	2,430 KW

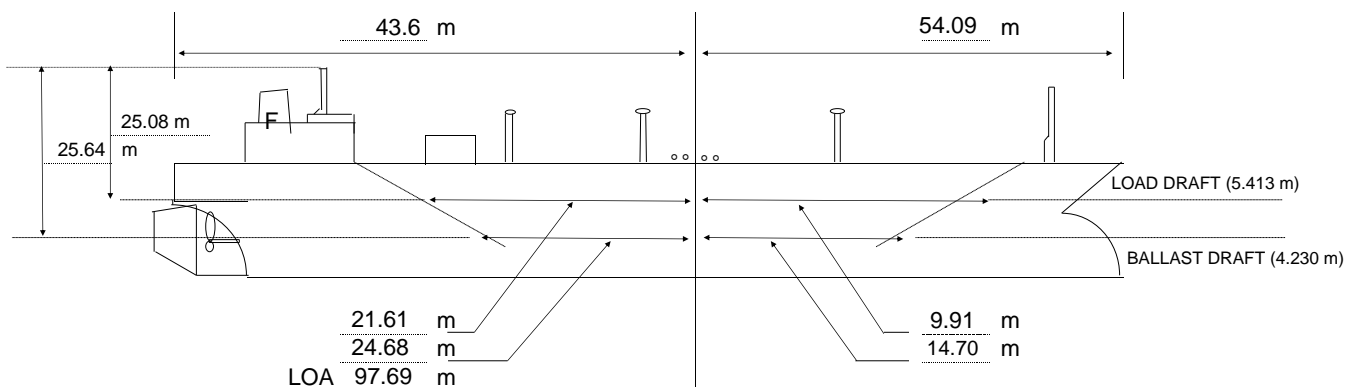
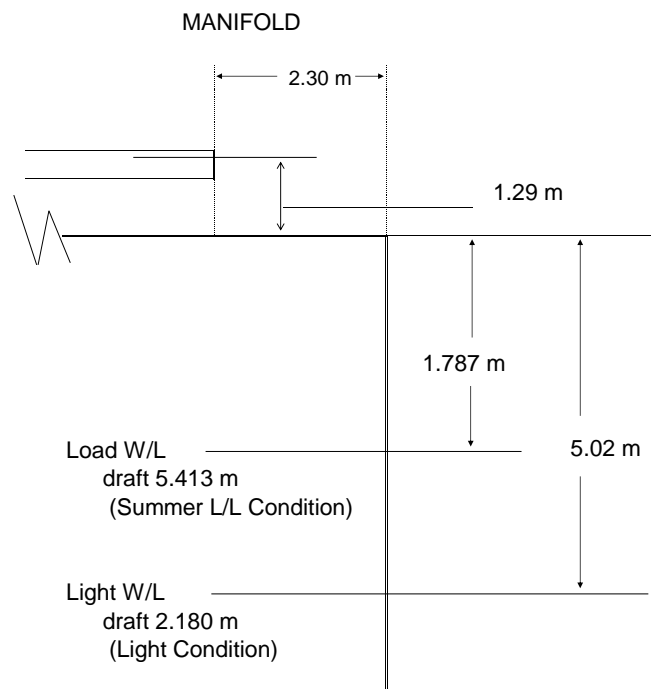
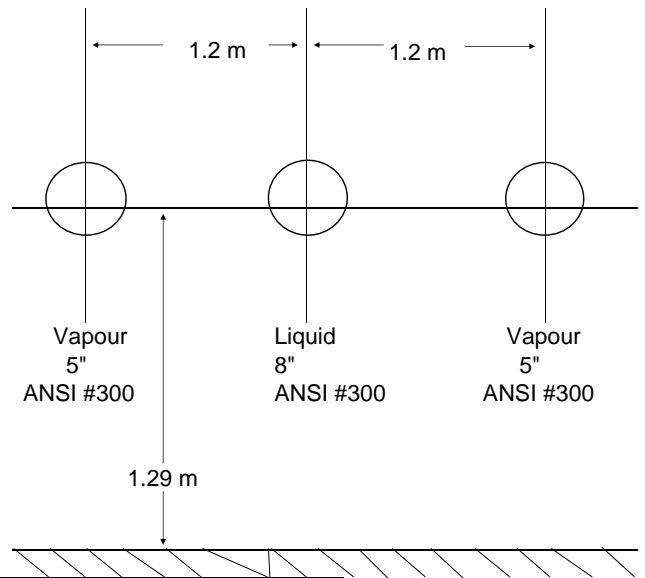

MANIFOLD