

SNO. 639	TAMARA		
TYPE	PRESSURIZED		
BUILT	37404		
FLAG	PANAMA		
CLASS	B.V.		
QUALIFICATION	IMO TYPE IIPG		
CALL. SIGN	HOEH		
TEL NO.	773 930 354		
FAX NO.	783 151 193		
DATA NO.			
E-MAIL ADDRESS	<a href="mailto:master.tamara@amosconnect.com">master.tamara@amosconnect.com</a>		
TELEX NO.	435 390 010		
DW(MT)	6,017.00		
INTERNATIONAL TONNAGE			
DOMESTIC TONNAGE	-		
NET TON	1,995.00		
LOA (M)	117.02		
BREADTH (M)	18.23		
DEPTH (M)	8.90		
SUMMER DRAFT (M)	6.80		
MAX DRAFT (M)	6.80M DISPLACEMENT 9,730.74 MT (6,241.74 DWT) IF0=649.2 M3, MDO=129.9 M3, F/W=152.9 M3, B/W=1,405.8 M3		
TANK CAPACITY (CBM) - 98% (NUMBER)	Total	7,077.059	
	No. 1	3,539.059	
	No. 2	3,538.139	
MAX. PRESSURE	1.77 Mpa (18.0 KG/CM2)		
MIN. TEMP.	0 DEG.C		
CARGO SEGREGATION	ONE GRADE		
LOADABLE CARGOES	PROPANE, PROPYLENE I-BUTANE, N-BUTANE P/B MIXTURES, ISOPRENE BUTADIENE, BUTYLENE PENTANE, PENTENE, VCM		
I.G.PLANT (CAPACITY) (CONTAINTS)	NITROGEN GENERATOR 340 m3/hr O2 : below 1,000ppm, CO2 : below 5ppm, N2+Ar : 99.9 vol %		
(LOWEST DEWPOINT ACHIEVABLE)	- 50 Deg.C		
CARGO RE-HEATER(TYPE) (NUMBER) (HEATING MEDIUM) (SPEC FOR PROPANE FROM - 45 TO 0 C)	/		
CARGO PUMPS(TYPE) (CAPACITY-CBM/HR) (NUMBER)			DEEPWELL 400 M3/Hr 2
CARGO COMPRESSORE (TYPE) (CAPACITY-CBM/HR) (NUMBER)			OIL-FREE 467 M4/Hr 2
MAIN ENGINE (SERVICE POWER)			DIESEL 3,900 KW

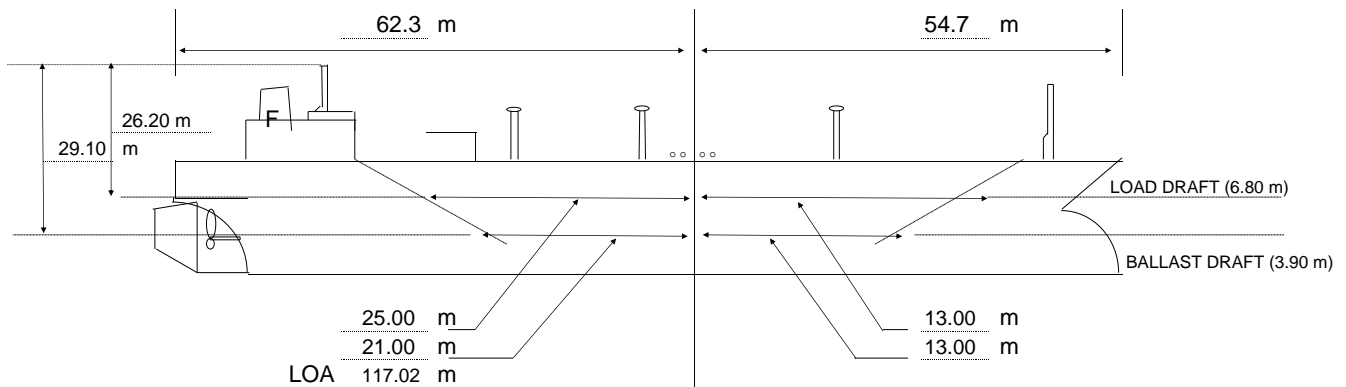
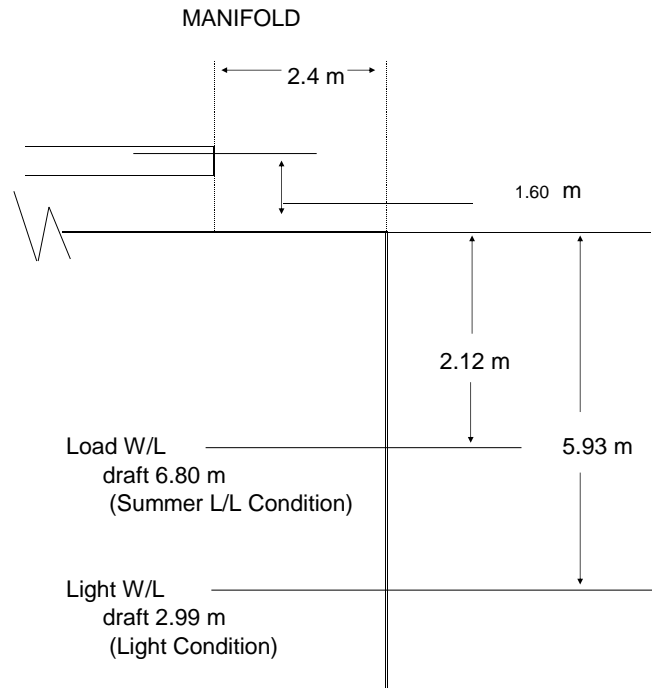
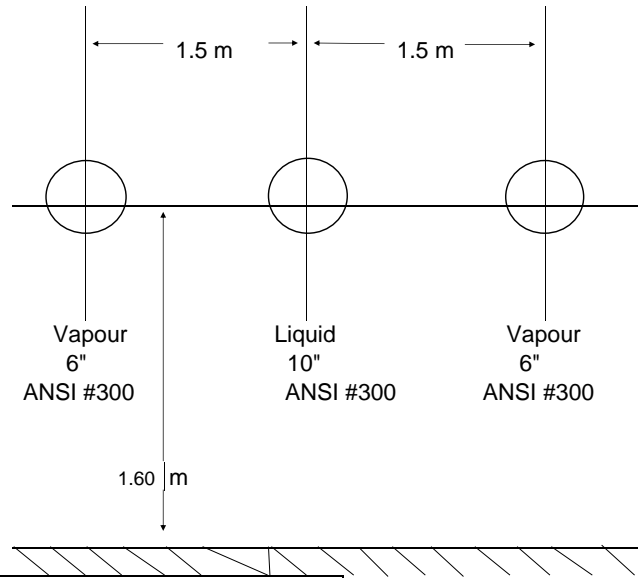

MANIFOLD